



2-CHANNELS

A high-efficiency, 2-channel constant voltage driver with full DALI D4i DT6/DT8 compatibility, offering flicker-free dimming from 0.2-100%. Designed for precise control and reliability, it features active PFC, built-in DALI bus power, and intelligent temperature and power monitoring – all in an IP66-rated housing for any environment.

FEATURES:

- Constant voltage output
- 100 - 277VAC (Universal) range
- Built-in Power Factor Correction (PFC) function
- Efficiency up to 93%
- Short circuit, over load, over temperature, over voltage protection
- Cooling by free air convection
- For dry, damp & wet locations, accord with IP66
- The dimming curve is adjustable, Multi-Channel output, Multiple frequency options, DT6 and DT8 compatibility
- Comes with DALI bus power supply and auxiliary power supply. Power status detection function (D4i function) and lamp temperature detection. Driver parameters can be adjusted in app
- DALI dimming (PWM Output)
- Min load is 10%
- Dimming range: 0.2%-100%(244Hz) 0.2%-100%(800Hz) 0.3%-100%(4KHz) 0.8%-100%(20KHz)
- 5 years warranty

DALI-96W-UNV-24VAO-D4IDT8-2CH-BK

Number of channels		2 CHANNELS	
LM Number		LM42900-27	
Output	DC Voltage	24V	
	Fine-tune voltage	24V - 26V	
	Voltage tolerance	± 3%	
	Voltage regulation	≤ 1%	
	Load regulation	1%	
	Rated current	4A	
	Rated power	96W	
Input	Voltage range	100 - 277VAC	
	Frequency range	47 - 63Hz	
	Power factor (typ.) @ full load	PF ≥ 0.99 @ 120VAC	PF ≥ 0.96 @ 277VAC
	THD (typ.) @ full load	≤ 6% @ 120VAC	≤ 8% @ 277VAC
	Efficiency (typ.) @ full load	91% @ 120VAC	93% @ 277VAC
	AC current (max.)	< 1A @ 120VAC	<0.5A @ 277VAC
	Inrush current (typ.) @ 50% I _{peak}	58A,134.4us @ 50%I _{peak} 120VAC	123A,205us @ 50%I _{peak} 277VAC
	Leakage current	<0.5mA	
Protection	Short circuit	Shut down o/p voltage, recovers automatically after fault condition is removed	
	Over load	≥ 115% Hiccup mode, recovers automatically after fault condition is removed	
	Over temperature	Ambient temperature over 55°C ± 5°C to reduce output to 50%; The ambient temperature drops to 45°C ± 5°C and automatically recovers. Ambient temperature over 75°C ± 5°C to reduce output to 0%; The ambient temperature drops to 45°C ± 5°C and automatically recovers.	
Environment	Working temperature	-40°C ~ +50°C	
	Working humidity	20-95% RH non-condensing	
	Storage temperature, humidity	-40°C ~ +80°C, 10-95% RH non-condensing	
	Temperature coefficient	±0.03% / °C(0°C - 50°C)	
	Vibration	10-500Hz, 5G 12min. / 1 cycle, period for 72min. each along X,Y,Z axes	
	Ambient temperature	50°C	
	Casing temperature	90°C	
Safety & EMC	Safety standards	UL8750 CAN/CSA-C22.2 No.250.13 (US)	
	Withstand voltage	I/P-O/P:1.88KVAC I/P-FG:1.88KVAC O/P-FG:0.5KVAC (US)	
	Isolation resistance	I/P-O/P:100MΩ / 500VDC / 25°C / 70% RH	
	EMC Emission	FCC Part 15, Subpart B; ANSI C63.4a-2017; ICES-005 Issue 5	
	Surge Immunity Test	AC Power Line:Differential Mode 4 kV, Common Mode 6 kV	
Weight & Dimensions	Net Weight	1.5kg	
	Dimensions	241 x 125 x 42.7mm (L x W x H)	

MCB recommendations		The number of LED Driver matched by circuit breakers is as follows:	
MCB Type	Level	Number of LED drivers @ 120 VAC	Number of LED drivers @ 277 VAC
C type (Breaking capacity:6KA)	10A	6	12
	13A	7	15
	16A	9	19
	20A	12	24
	25A	15	29

1. The above quantities of the led drivers connected on the Type C is recommended base on the maximum ambient temperature is 50 °C

2. The breaker should be selected according to the input rated voltage, input rated current, ambient temperature, and trip characteristic curve.

EFFICIENCY CURVE

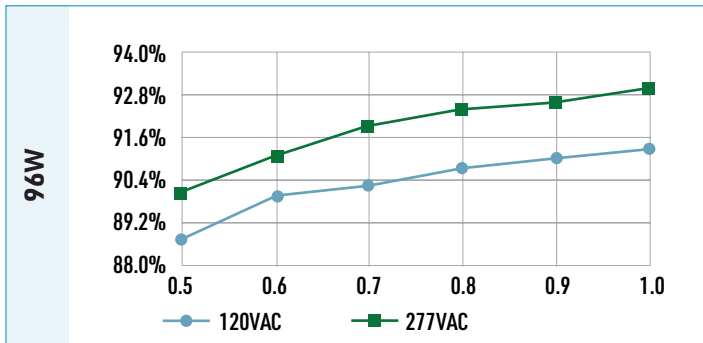

POWER FACTOR CURVE

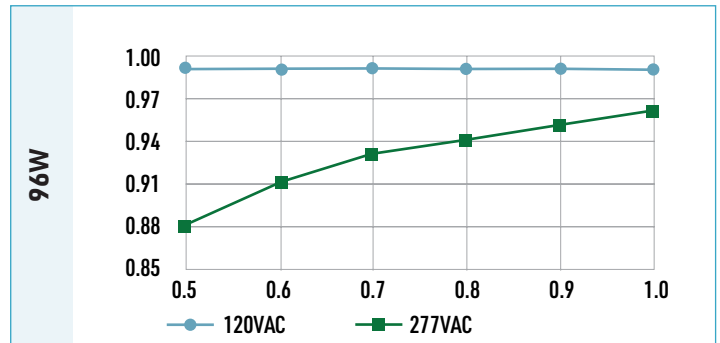

DERATING CURVE (OUTPUT POWER VS. AMBIENT TEMP.)

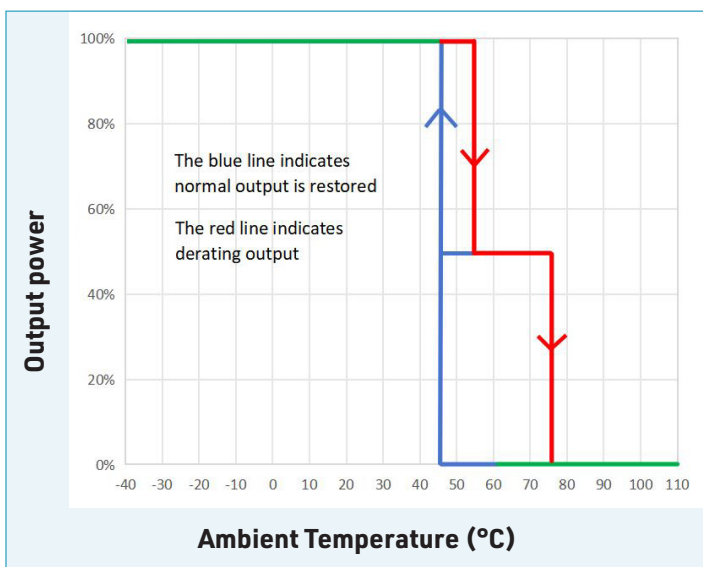

DERATING CURVE OF LAMP (OUTPUT POWER VS. LAMP)

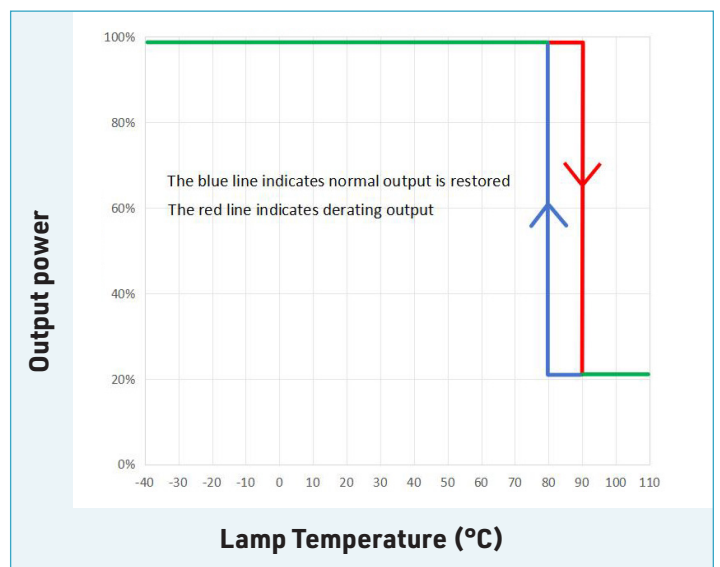

- To extend their life, please refer to the Derating Curve and derate according to the temperature.
- The output current of the LED driver should be selected according to the rated current of the lamp and the ambient temperature.
- Normally, we recommend the power supply to reserve a certain amount of load to extend LED driver's life .

- This figure shows the protection curve when the recommended model of the lamp temperature sensor is NCP18XH103J03RB(muRata) and the external temperature protection parameters on the APP are factory default.
- If the model of thermistor is not NCP18XH103J03RB(muRata) , Please check the relevant parameters of lamp temperature protection on the APP.
- 3. If the lamp temperature sensor is not connected, please keep the parameters of the lamp temperature protection section on the APP as default and cap the wires so they don't contact the housing.

DIMENSIONS

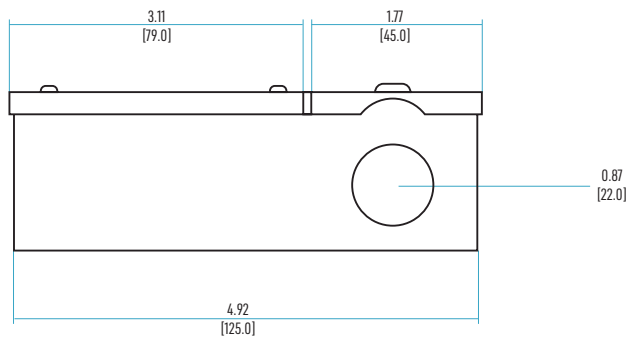
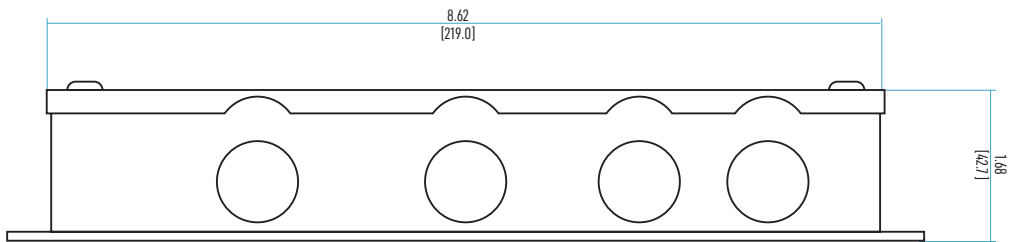
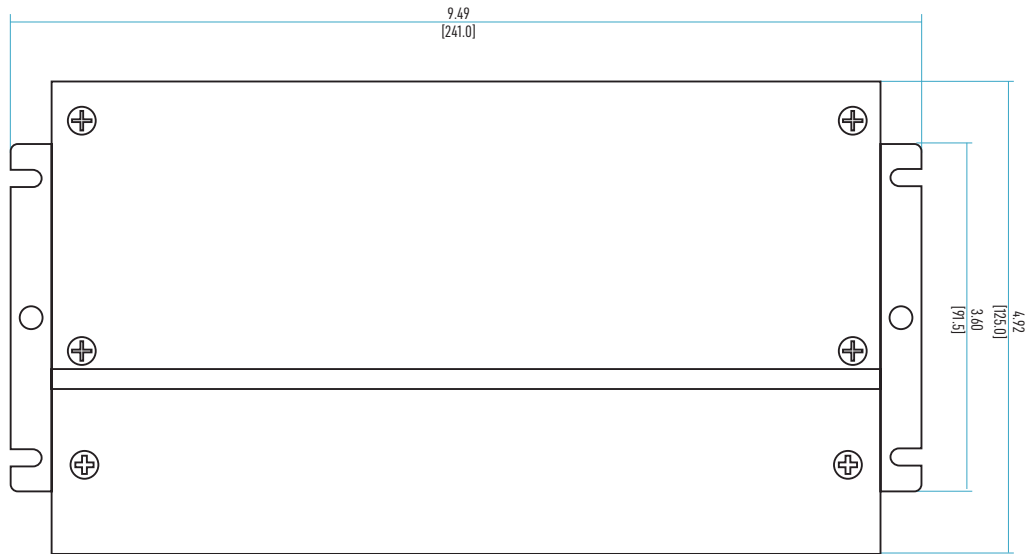

DT8 CONNEXION - 1 TUNEABLE WHITE LED LUMINAIRE

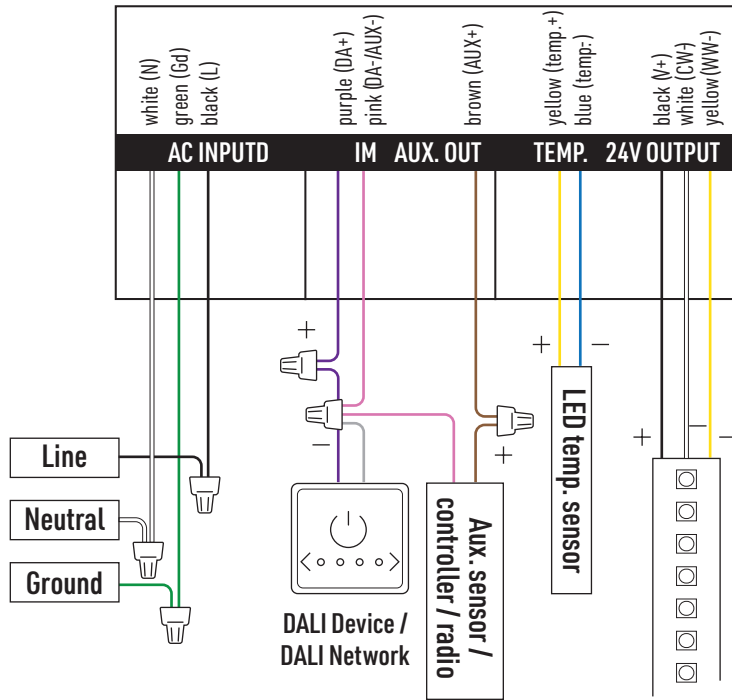

GETTING STARTED

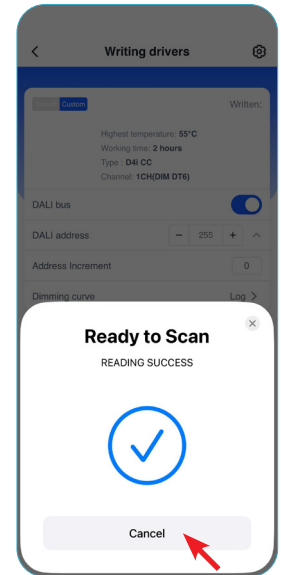
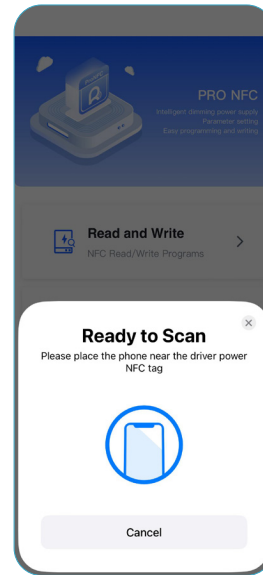
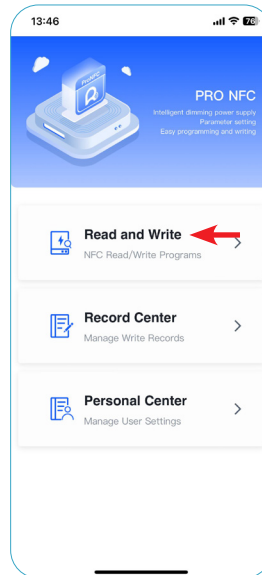

1. Scan the QR-code below or follow this link to download the ProNFC app [for iOS](#) or [Android](#). This app will help you set up and control your device.

2. Open the ProNFC APP. Click on the "Read and Write".

3. Use the phone's NFC sensing area close to the driver's NFC symbol.

4. Wait for the successful reading. Stop further scanning by pressing "Cancel".

DALI ADDRESS & DALI BUS

Address setting: Set the DALI address parameter of current power supply, address setting range: 0~63,255 (255 means delete address).

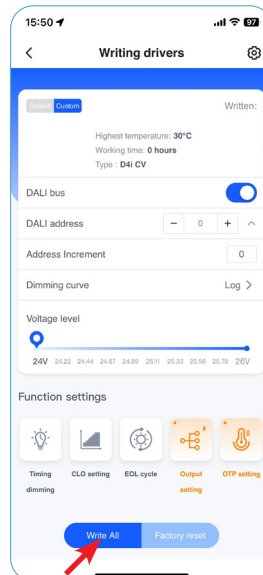
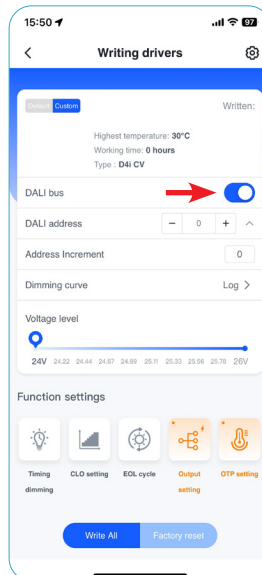
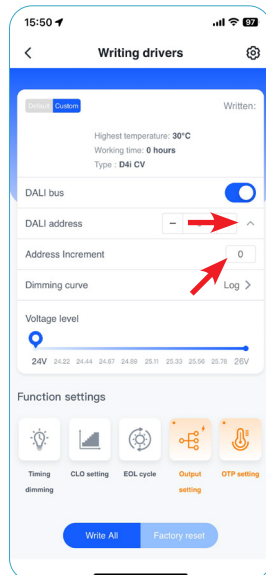
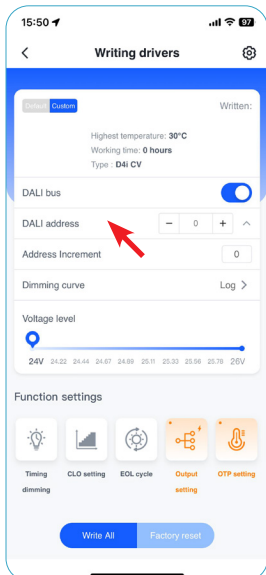

1. Click the + or - sign of DALI address in the main page to set the address, and click the value box in the middle to input the value 0-63,255.

2. Click an arrow next to the DALI address to collapse or expand the address auto-increment setting below, input the value 0-10 to auto-increment the address, 0 is to close the auto-increment.

3. Click on the DALI bus switch to enable or disable the DALI bus setting.

4. Click "Write All" to program and write the set parameters and take effect **after the driver power supply is re-powered.**

DIMMING CURVE ADJUSTMENT

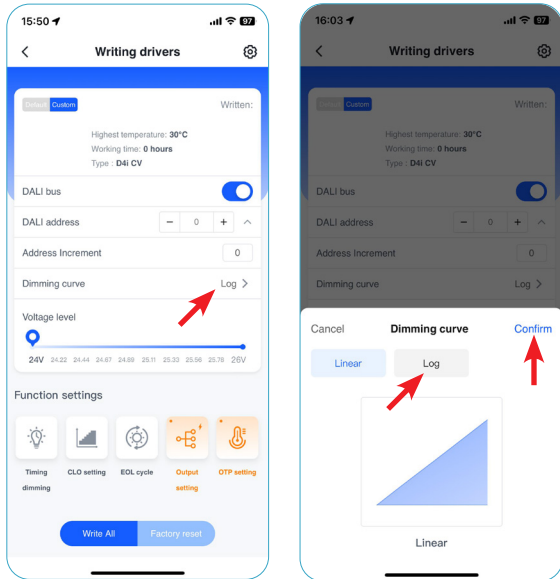

1. Click on the current dimming curve in the function homepage to activate the pop-up window to change the dimming curve parameters.
2. Select the dimming curve you want to set in the pop-up window page.
3. Click "Confirm" to save and close the pop-up page.

OUTPUT VOLTAGE ADJUSTMENT

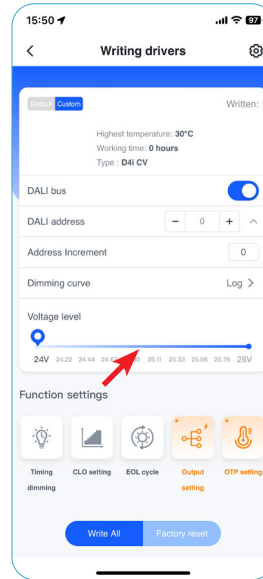

NFC Voltage Regulation Level	
Level 1	24.0V
Level 2	24.2V
Level 3	24.4V
Level 4	24.7V
Level 5	24.9V
Level 6	25.1V
Level 7	25.3V
Level 8	25.6V
Level 9	25.8V
Level 10	26.0V

The output voltage can be read and written by a mobile with ProNFC APP by placing it close to the NFC signal area of the driver.

SET OUTPUT MODE (DT6 / DT8) BY NFC

DALI DT6 for single color or DALI DT8 for CCT Tunable white can chosen by ProNFC.

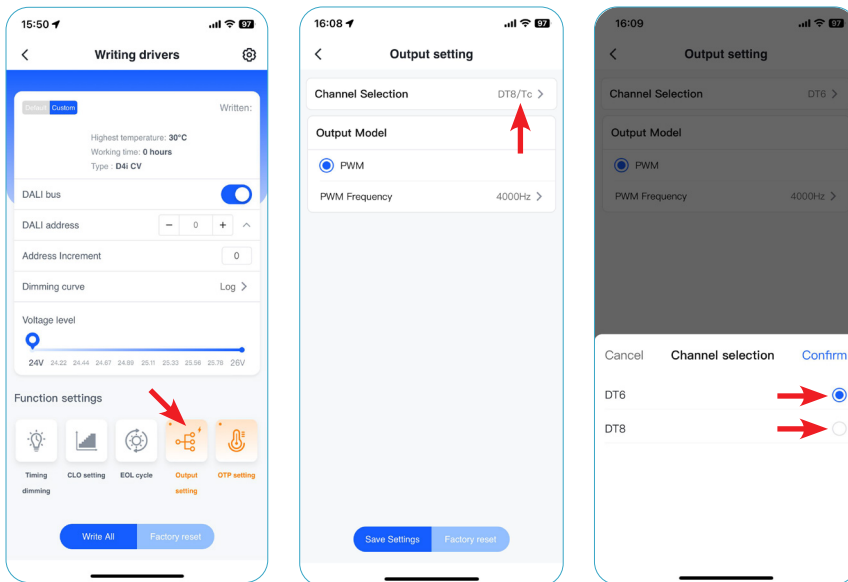

OUTPUT SETTING/PWM FREQUENCY

Select the desired PWM frequency setting of the drive power supply according to the project requirements.

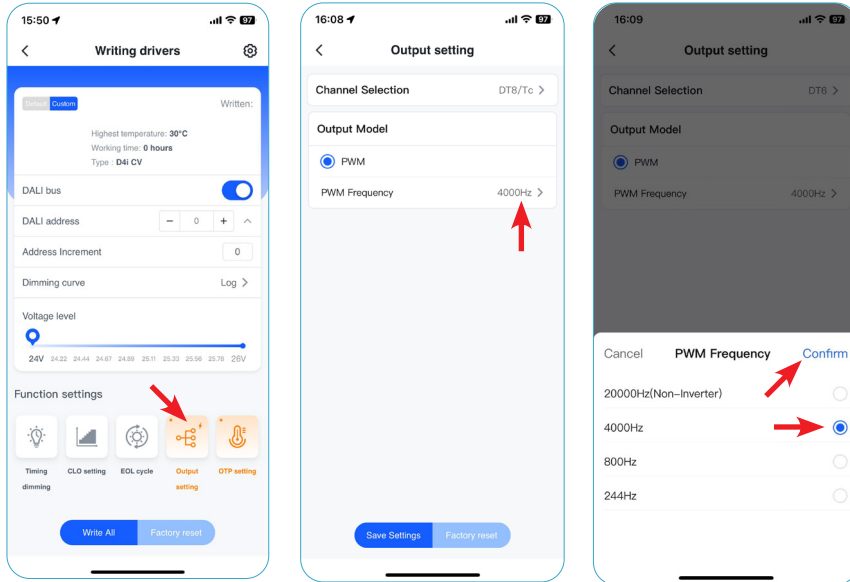

1. Click "Output Settings" on the main page of the function.
2. Click the PWM frequency pop-up window.
3. Select the PWM frequency and click "Confirm".

TIME DIMMING

Time dimming control includes 3 kinds of modes, they are self adapting-midnight, self adapting percentage and traditional timer. Three modes can be set via NFC.

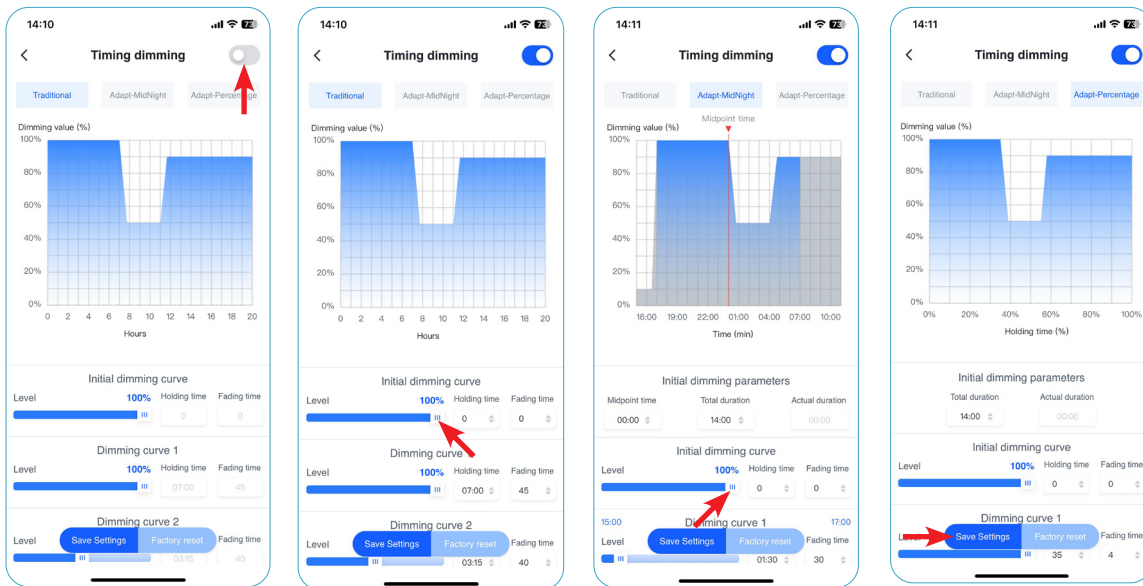

1. **Traditional Timer:** follows the programmed timing curve after power on with no changes.
2. **Self Adapting - Midnight:** set the midpoint time of the dimmer curve, it will automatically adjust the curve according to the total working time of the past few days, if difference <30 minutes (the midpoint is set at 0 point, the user can set the offset, can be positive and negative offset for 4 hours).
3. **Self Adapting-Percentage:** automatically adjust the working hours according to the last few days (increase or decrease according to the initialization time and effective working time).

CLO SETTING

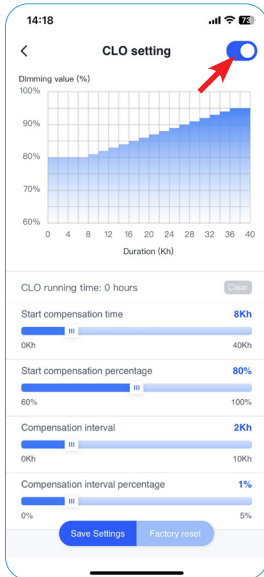

This function is mainly used to maintain the constant brightness output of the LED. During the life cycle of LED, by gradually increasing the driving current, to compensate for the light decay caused by the long operation of LED, ensuring the constant optical flux output of LED.

EOL CYCLE

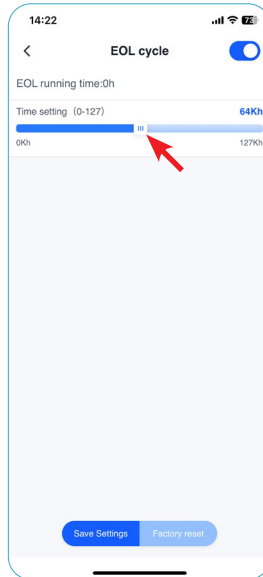

Once this function is activated, the output current of the LED drive automatically decreases to 1% of the total current and lasts for 1 minute, reminding the user to replace the LED fixture and reaching the service life designed by the supplier.

OVER-TEMPERATURE PROTECTION



During use, if the power supply detects that the external temperature of the luminaire exceeds the preset threshold, it will automatically trigger the over-temperature protection and reduce the power supply current value to avoid the luminaire from overheating and causing damage.

WARNING

- Installation must be performed by a qualified electrician or professional installer in accordance with applicable electrical codes.
- Ensure adequate ventilation around the driver to allow for proper heat dissipation.
- Verify all wiring connections before powering on to prevent damage to the LED load or power supply.
- Do not attempt to repair or modify the driver. Contact your distributor or qualified service personnel if the unit does not operate properly.

UNDERSTANDING PWM (PULSE WIDTH MODULATION)

Pulse Width Modulation (PWM) is a method for reducing the average deliverable power of an electrical signal. PWM dimming works by rapidly switching the LED on and off at high speed. The PWM signal may either be ON or OFF at any one time, meaning that the LEDs will either get the full or no voltage. The brightness is controlled by adjusting the time the LED is on versus off in each cycle. Since this happens faster than the human eye can detect, the LED appears to dim smoothly without changing its voltage. Best for commercial applications, ensures high-efficiency, precise dimming and color consistency for advanced lighting systems.

Benefits:

- Maintains consistent LED color and efficiency across dimming levels
- Provides smooth and precise dimming

Considerations:

- Low-quality dimmers may introduce flicker if the frequency is too low

Dimming Compatibility:

- 0-10V Dimming: the 0-10V signal is converted into a corresponding PWM signal to control brightness
- Phase-Cut Dimming: can work with MLV and ELV dimmers by interpreting the phase-cut signal to adjust the PWM duty cycle

CLASS P DRIVERS

A **Class P driver** is a type of LED driver that follows **UL (Underwriters Laboratories)** standards for safety and performance. The main benefit is **interchangeability** – you can replace a Class P driver with another Class P driver (from any brand) **with same specifications** without needing to retest the entire lighting system for compliance.

Key Points:

- **Interchangeability** – Makes it easier to replace drivers without re-certification.
- **UL Safety Standard** – Ensures the driver meets thermal and electrical safety requirements.
- **Flexibility** – Manufacturers can switch to different Class P drivers based on availability or performance needs.