





### THE COMPLETE FAMILY OF ADJUSTABLE VOLTAGE OUTPUT DRIVERS

The LTE series offers the range of 30W, 60W, 96W, 192W (96W x 2) and 288W (96W x 3) drivers with 24V adjustable output. The voltage output adjustment (up to 26V) allows to compensate possible voltage drops when you need longer wire leads between your driver and your lighting application.

#### FEATURES:

- Constant voltage output
- Flicker-free dimming
- 100 - 277VAC (Universal) range
- Available in 30W, 60W, 96W, 192W and 288W
- Built-in Power Factor Correction (PFC) function
- Easy field voltage adjustment
- Efficiency up to 84%
- Short circuit, over load, over temperature protection
- Cooling by free air convection
- Full aluminum protection housing for dry, damp and wet locations
- Phase dimming: forward phase, MLV, reverse phase, ELV, TRIAC
- 0-10V dimming: 0 - 10V / 1 - 10V / Potentiometer / 10V Power Width Modulation (PWM) 4 in 1
- Dimming range 0 - 100%, dimming depth 0.1%
- High efficiency, smaller size, high power factor, low THD
- Surface installation
- 5 years warranty

# LTE-XXW-UNV-24VAO-PH010-BK

		30W	60W	96W	192W (96W x 2)	288W (96W x 3)
<b>LM Number</b>		LM42900-01	LM42900-02	LM42900-03	LM42900-04	LM42900-05
<b>Output</b>	DC Voltage	24V	24V	24V	24V	24V
	Voltage tolerance	±3%	±2.5%	±2%	±0.5%	±0.5%
	Voltage regulation	≤0.5%	≤0.5%	≤0.5%	≤0.5%	≤0.5%
	Load regulation	≤1%	≤1%	≤0.5%	±1%	±1%
	Rated current	1.25A	2.5A	4A	2 x 4A	3 x 4A
	Rated power	30W	60W	96W	192W (2 x 96W)	288W (3 x 96W)
	Voltage ripple	400mVp-p	450mVp-p	296mVp-p	-	-
	Overshoot voltage	<10% (full load)	<2% (full load)	<3% (full load)	-	-
	Output voltage adjustment	24 - 26V 	24 - 26V 	24 - 26V 	24 - 26V 	24 - 25.5V 
	Output mode selection	The DIP switch in the "ON" position represents the PWM (Pulse - Width Modulation) mode, and in the "1" position represents the VR (Modulation of DC Voltage) mode.				
	Switching the output mode requires the power to be cut off for 3 seconds and then powered on again for the mode switching to take effect.					
<b>Dimming</b>	Phase dimming	Forward phase /leading edge, MLV and Reverse phase /trailing edge, ELV, TRIAC				
	0-10V dimming	0-10V/1-10V/Potentiometer/10V PWM 4 in 1				
	Min. load	20%	20%	20%	15%	15%
	Dimming range	0 - 100%	0 - 100%	0 - 100%	0 - 100%	0 - 100%
<b>Input</b>	Voltage range	110 - 277VAC	110 - 277VAC	110 - 277VAC	110 - 277VAC	110 - 277VAC
	Frequency range	47 - 63Hz	47 - 63Hz	47 - 63Hz	47 - 63Hz	47 - 63Hz
	Power factor (typ.) @ full load	>0.98@120VAC >0.95@277VAC	>0.98@120VAC >0.97@277VAC	>0.98@120VAC >0.97@277VAC	>0.99@120VAC >0.94@277VAC	>0.99@120VAC >0.94@277VAC
	THD (typ.) @ full load	<15%@120VAC <15%@277VAC	<15%@120VAC <15%@277VAC	<15%@120VAC <15%@277VAC	<20%@120VAC <20%@277VAC	<20%@120VAC <20%@277VAC
	Efficiency (typ.) @ full load	≥80%@120VAC ≥83%@277VAC	≥83%@120VAC ≥85.5%@277VAC	≥88%@120VAC ≥91.5%@277VAC	≥90%@120VAC ≥92%@277VAC	≥90.5%@120VAC ≥92%@277VAC
	AC current (max.)	≤0.4A@120VAC ≤0.16A@277VAC	≤0.75A@120VAC ≤0.3A@277VAC	≤1.0A@120VAC ≤0.43A@277VAC	2.2A	3.1A
	Standby power	≤0.5W	≤0.5W	≤0.5W	≤0.5W	≤0.5W
	Inrush current (typ.) @ 50% Ipeak	25A,120us@120V 60A,136us@277V	31.6A,152us@120V 76.8A,156us@277V	51A,208us@120V 118A,452us@277V	23A,1.3ms@120V 49A,960us@277V	38A,640us@120V 79A,920us@277V
	Leakage current	<0.5mA	<0.5mA	<0.5mA	<0.5mA	<0.5mA
	<b>Protection</b>	Short circuit	Hiccup mode, recovers automatically after fault condition is removed.			
Over load		≤120% Hiccup mode, recovers automatically after fault condition is removed.				
Over temperature		When the ambient temperature exceeds 55 ±5, the output is turned off.			100 ±10 shut down o/p voltage, automatically recover after cooling.	
<b>Environment</b>	Working temperature	-40°C ~ +40°C	-40°C ~ +40°C	-40°C ~ +40°C	-40°C ~ +60°C	-40°C ~ +60°C
	Working humidity	20-95% RH non-condensing	20-95% RH non-condensing	20-95% RH non-condensing	20-95% RH non-condensing	20-95% RH non-condensing
	Storage temperature, humidity	-40°C ~ +80°C, 10-95% RH non-cond.	-40°C ~ +80°C, 10-95% RH non-cond.	-40°C ~ +80°C, 10-95% RH non-cond.	-40°C ~ +80°C, 10-95% RH non-cond.	-40°C ~ +80°C, 10-95% RH non-cond.
	Temperature coefficient	±0.03% / (0°C - 50°C)	±0.03% / (0°C - 50°C)	±0.03% / (0°C - 50°C)	±0.03% / (0°C - 50°C)	±0.03% / (0°C - 50°C)
	Vibration	10 ~ 500Hz, 5G 12 minutes/cycle, X Y Z axis 72 minutes each	10 ~ 500Hz, 5G 12 minutes/cycle, X Y Z axis 72 minutes each	10 ~ 500Hz, 5G 12 minutes/cycle, X Y Z axis 72 minutes each	-	-
<b>Safety &amp; EMC</b>	Safety standards	UL8750 CAN/CSA-C22.2 No.250.13			UL8750 CAN/CSA-C22.2 No. 250.13 (US)	
	Withstand voltage	I/P-O/P:1.88KVac I/P-FG:1.88KVac O/P-FG:0.5KVac			I/P-O/P:1.8KVAC I/P-FG:1.8KVAC O/P-FG:1.8KVAC (US)	
	Isolation resistance	I/P-O/P:100MΩ / 500VDC / 25°C / 70% RH			I/P-O/P:100MΩ / 500VDC / 25°C / 70% RH	
	EMC Emission	FCC Part15 Subpart B ANSI C63.4: 2017 ICES-005 Issue 5			FCC 47 CFR Part 15, Subpart B (US)	
	Surge Immunity Test	AC Power Line: Differential Mode 2KV, Common Mode 4KV			Different mode: 2KV, Common mode: 4KV	
<b>Weight &amp; Dimensions</b>	Net Weight	0.75kg	0.94kg	1.0kg	1.55kg	2.15kg
	Dimensions	170.5 x 116.5 x 42mm (L x W x H)	196.5 x 103.4 x 40mm (L x W x H)	196.5 x 103.4 x 40mm (L x W x H)	232 x 116 x 40mm (L x W x H)	275 x 116 x 40mm (L x W x H)

## DIMMING CURVE

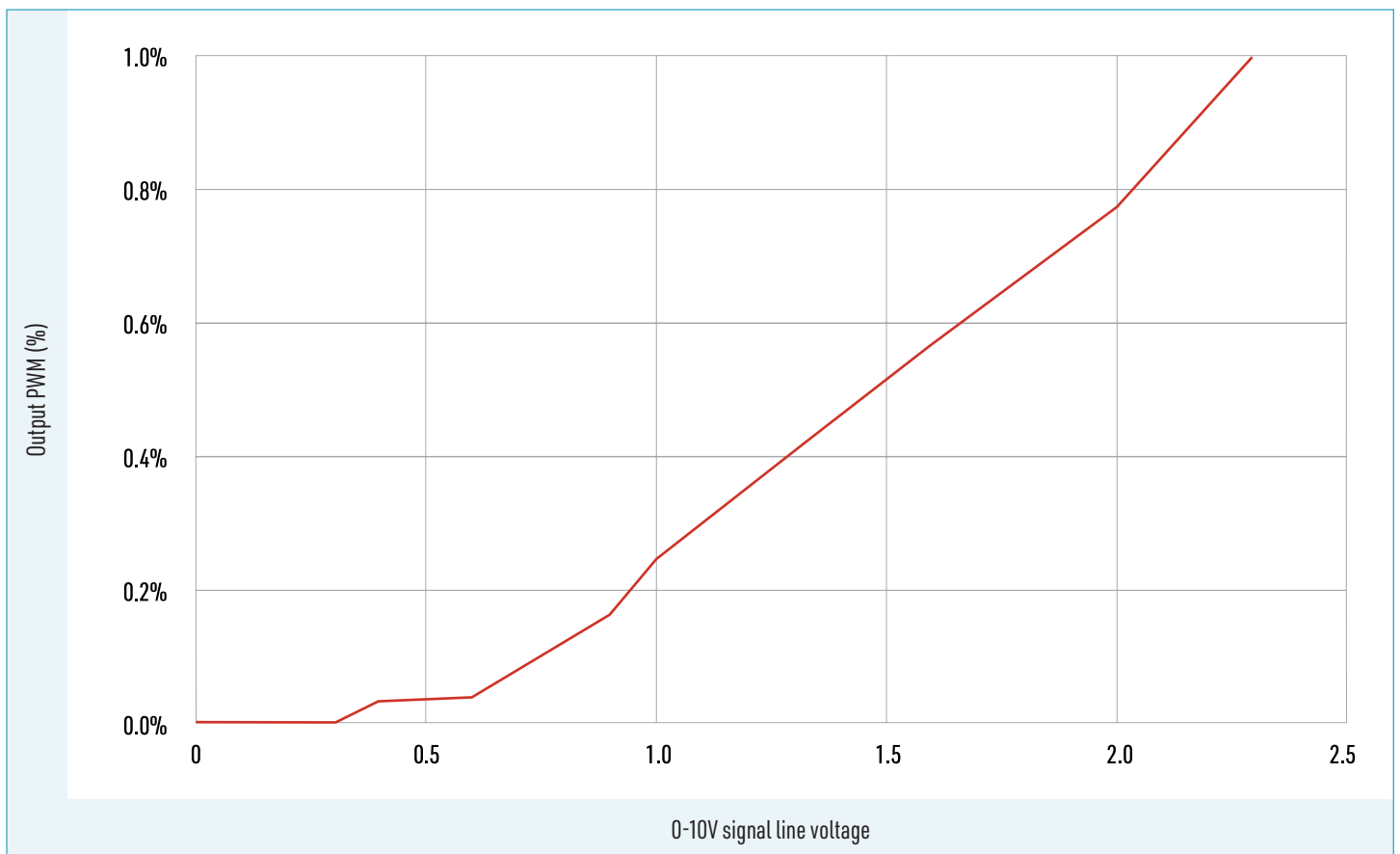
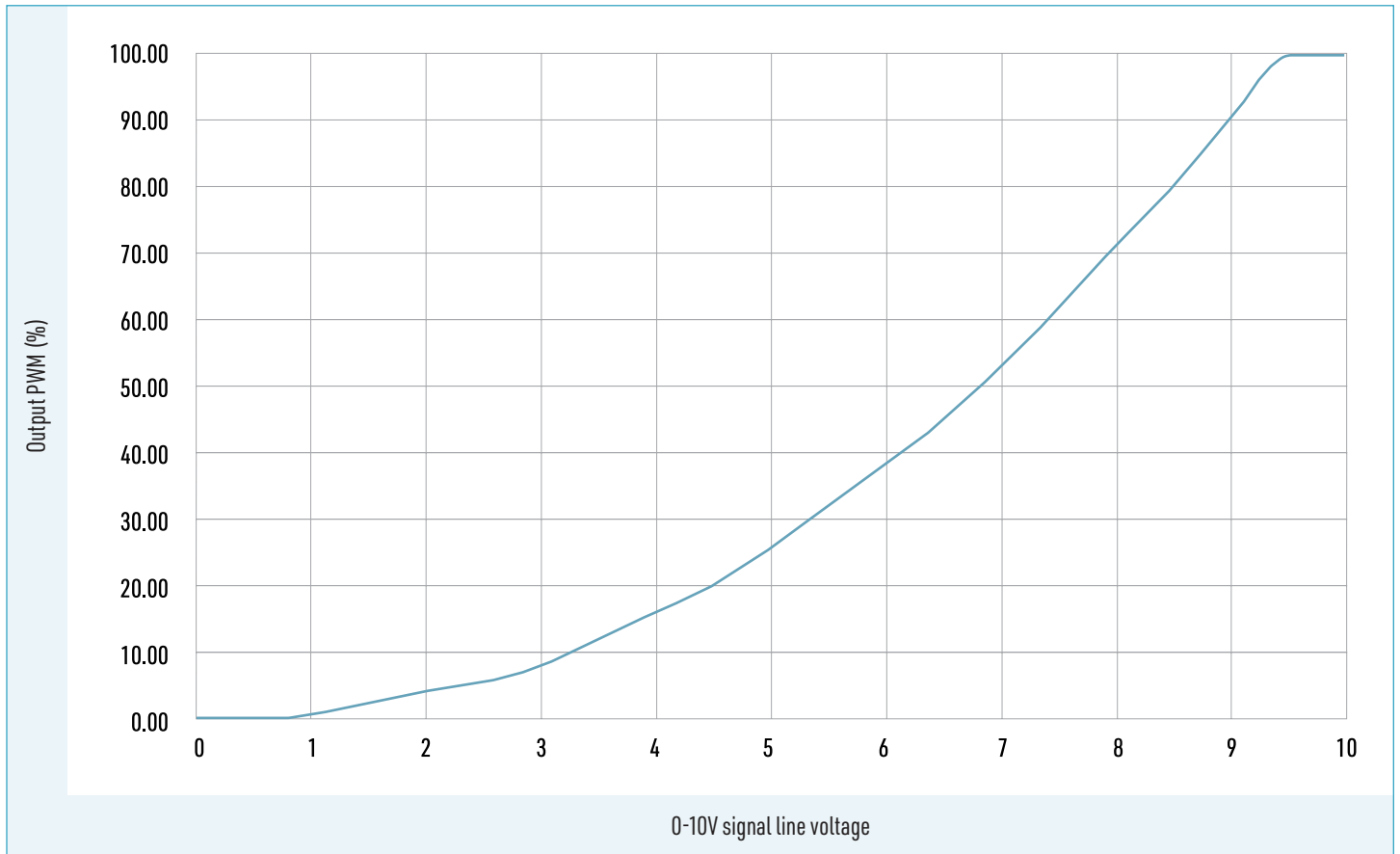

## EFFICIENCY CURVE

## POWER FACTOR CURVE

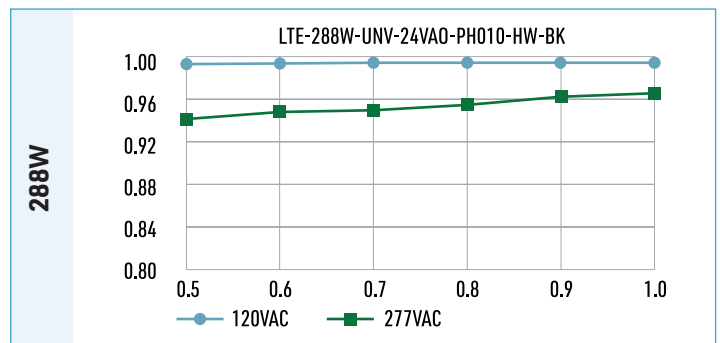
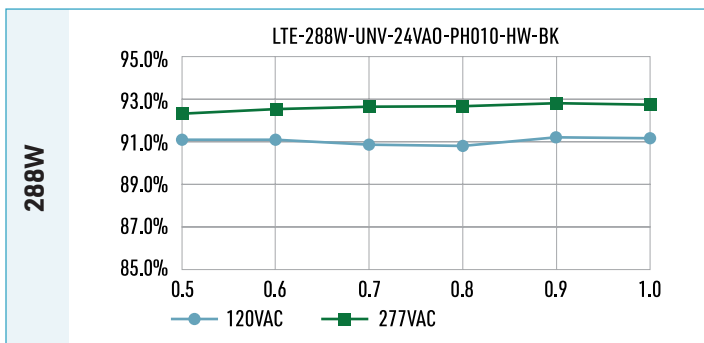
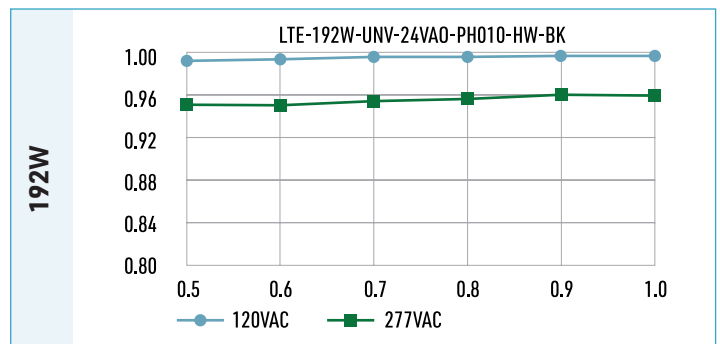
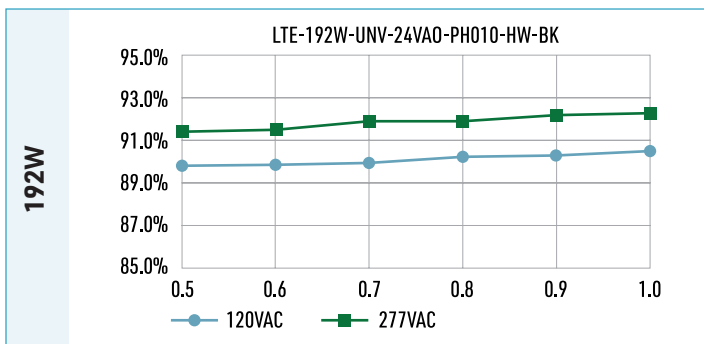
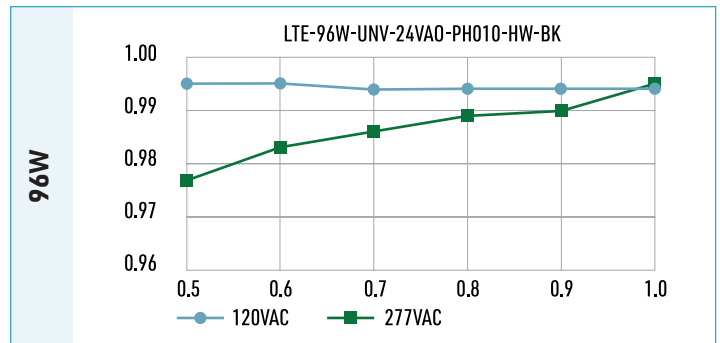
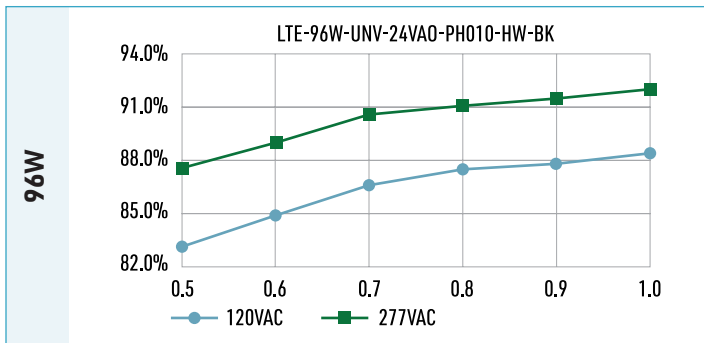
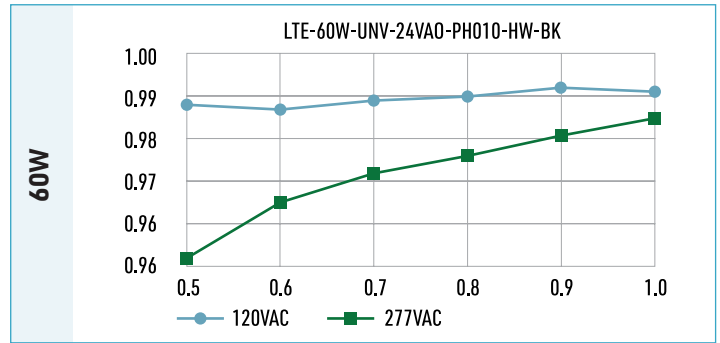
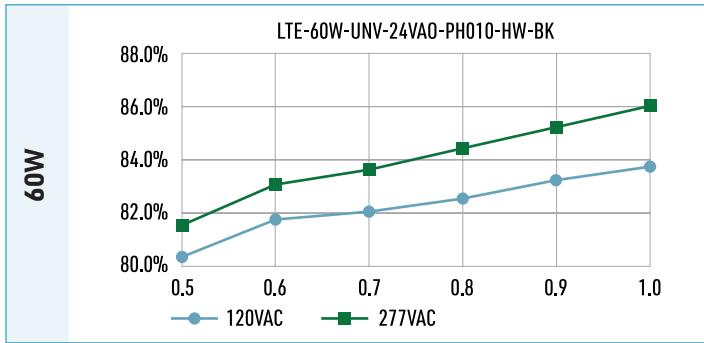
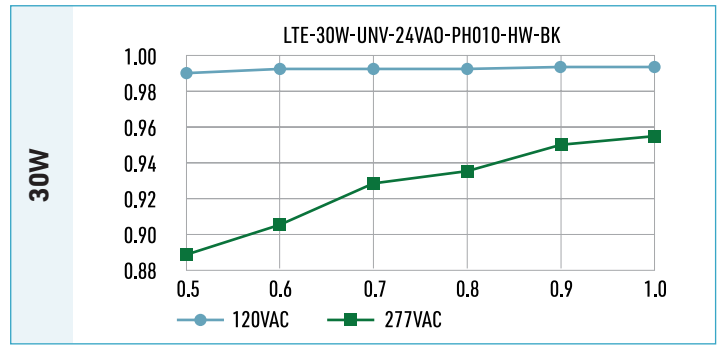
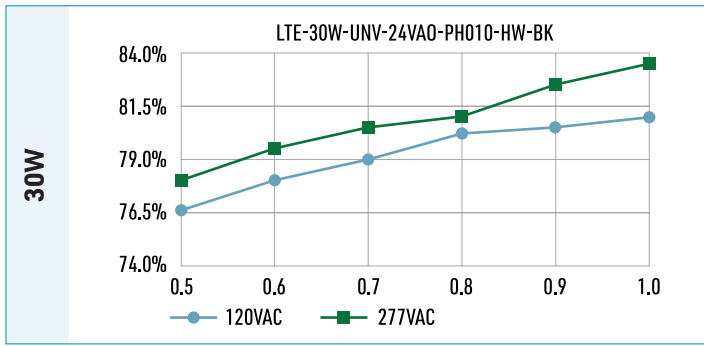

# DIMENSIONS - 30W

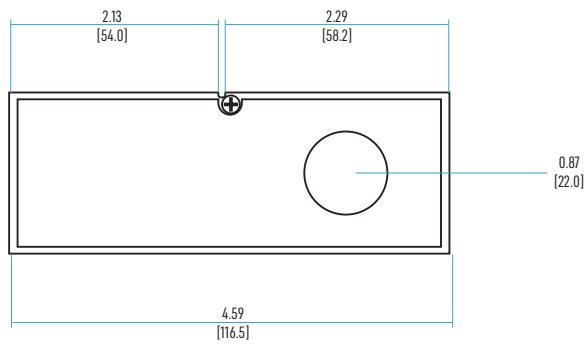
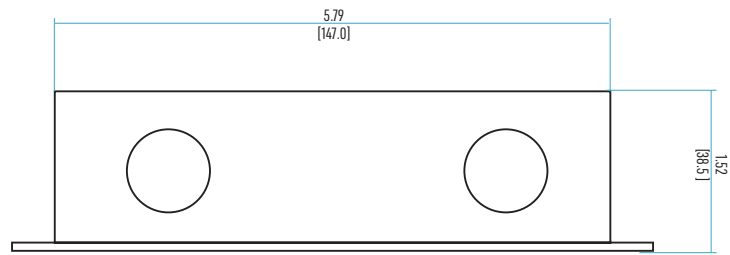
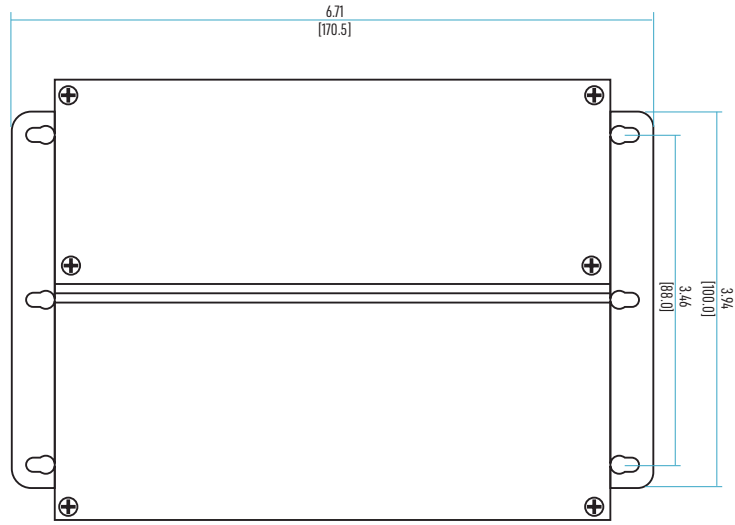

# DIMENSIONS - 60W / 96W

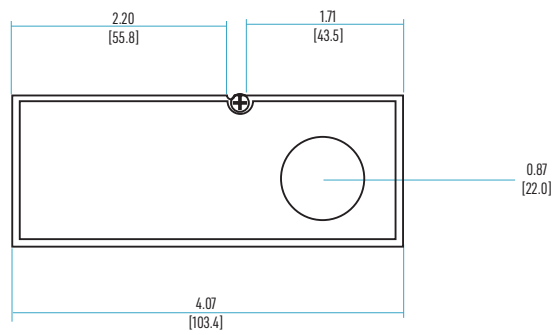
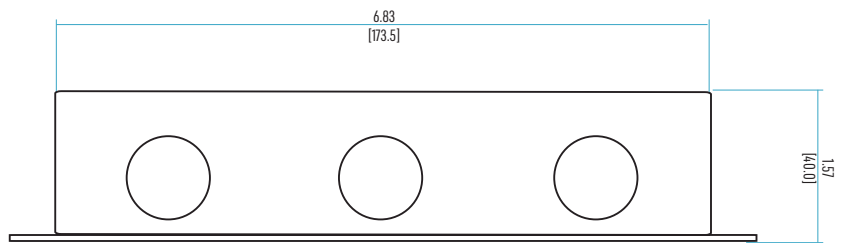
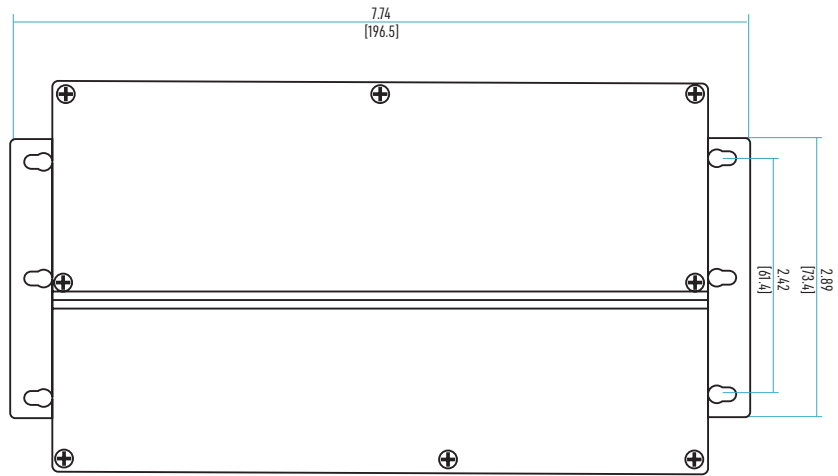

# DIMENSIONS - 192W

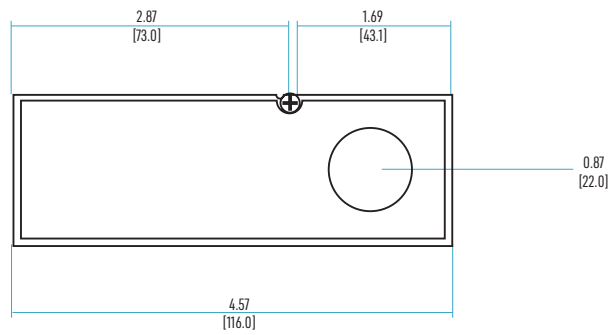
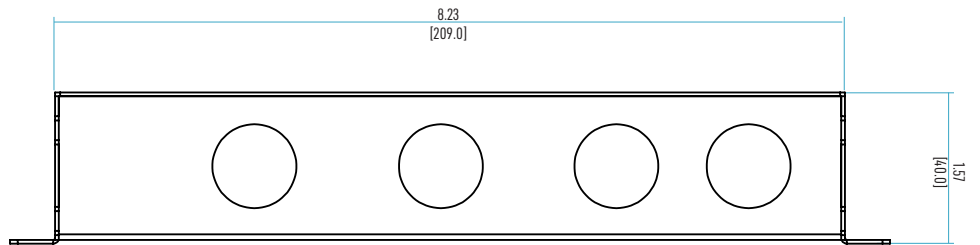
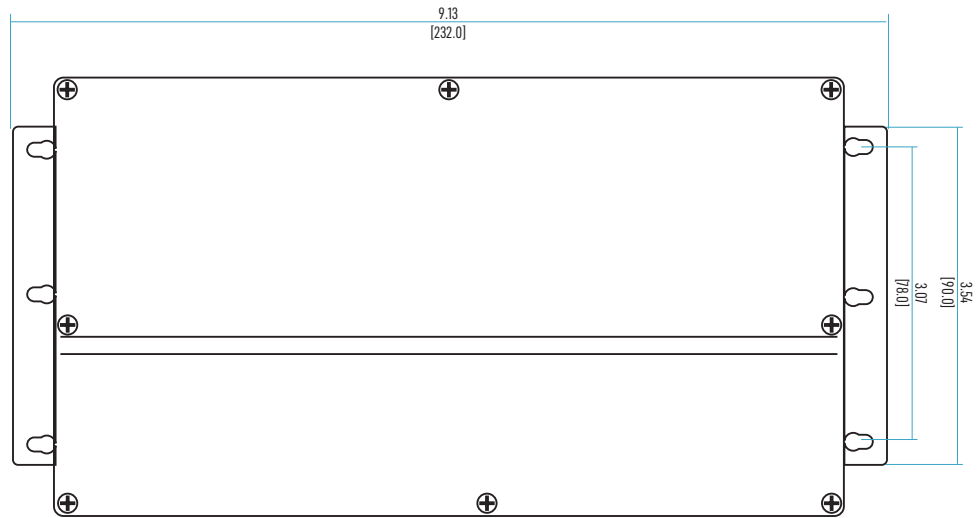

# DIMENSIONS - 288W

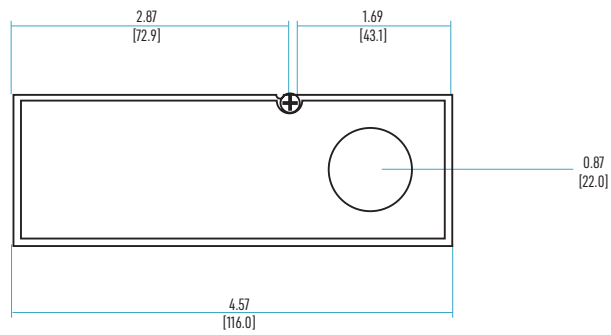
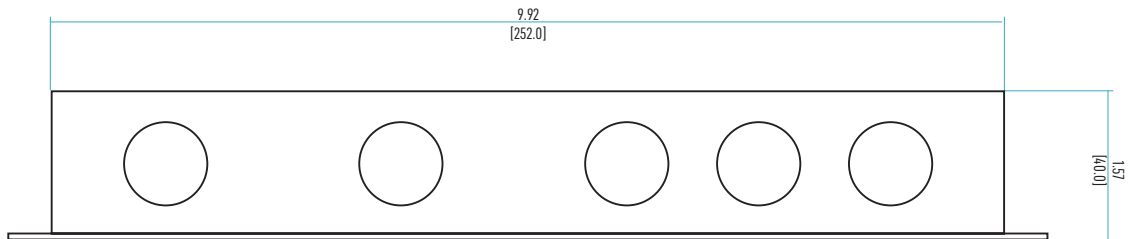
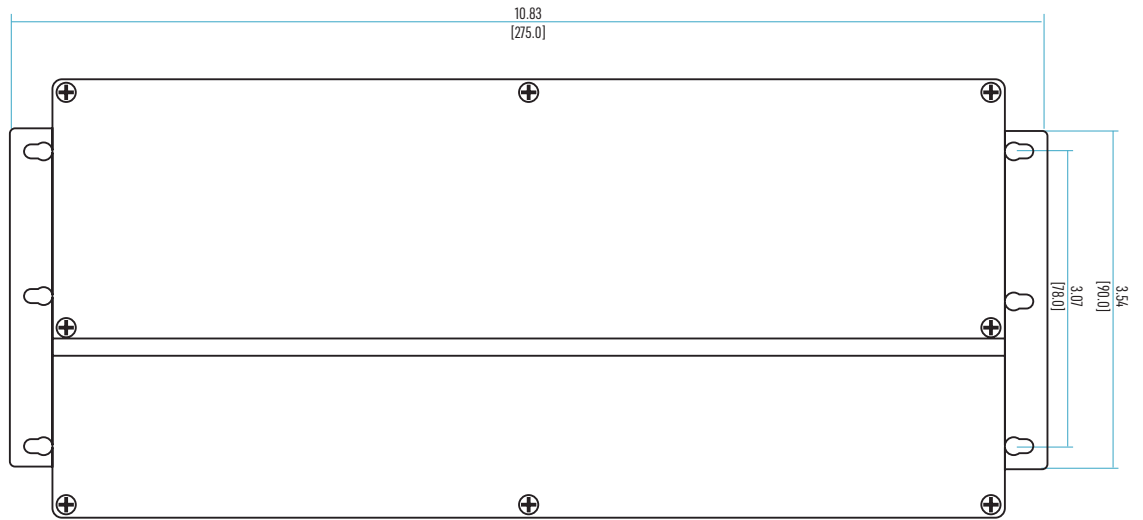



## DRIVER INSTALLATION

### WHEN INSTALLING MULTIPLE DRIVERS SIDE-BY-SIDE

It is important to leave a gap of at least **3 inches (76mm)** between them in order to prevent overheating.

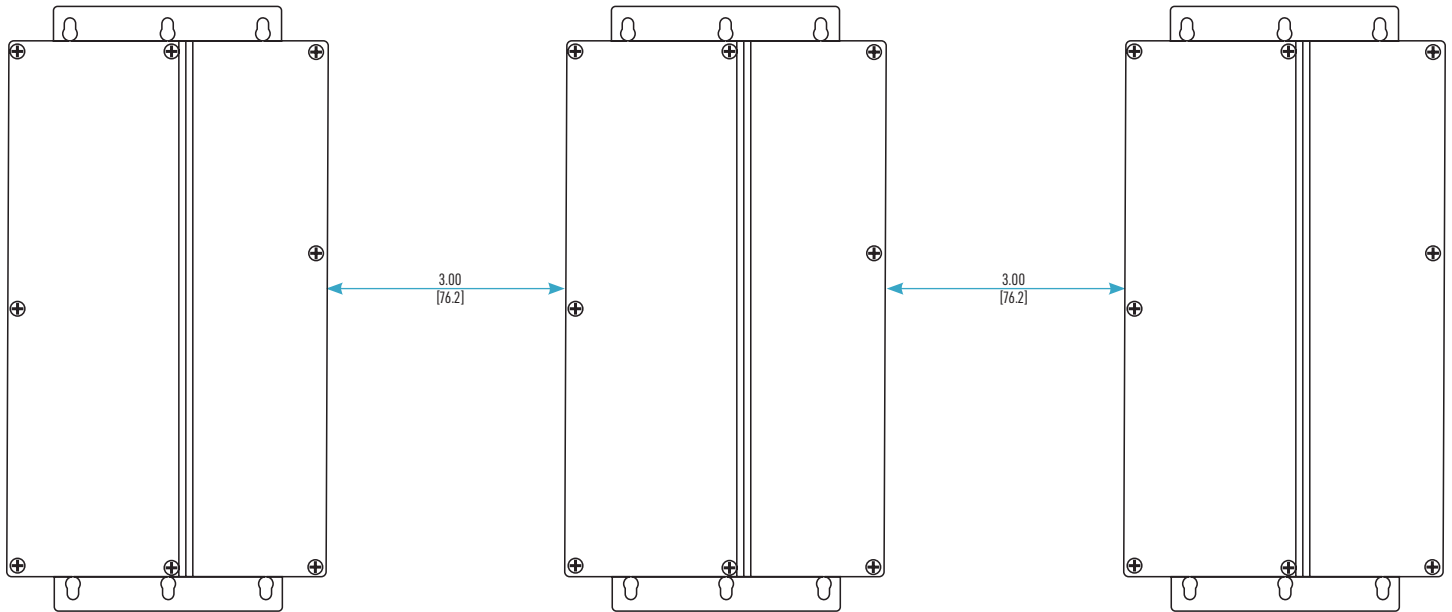

### WIRING COMPARTMENT

is separated into UNV (110-277V AC) input, 0-10V dimming and 24V DC output sections\*

Use appropriate knock-outs to make the electrical connections. Follow the wiring diagram on the next page.

### VOLTAGE ADJUSTMENT KNOB (A.)

is used to adjust output voltage (up to 26V) to compensate any possible voltage drops in long runs of wiring or LED application.

Use voltmeter at the end of your LED application run and adjust the knob until the output voltage is or close to 24V.



### DIMMING MODE SWITCH (B.)

is used to switch between Pulse Width Modulation (PWM) and Voltage Regulation (VR) (see the last page for details).

Switching the output mode requires the power to be cut off for 3 seconds and then powered on again for the mode switching to take effect.



AC INPUT 110-277V AC

0-10V DIMMING

24V DC OUTPUT\*\*

\*In 30W driver, 0-10V dimming and 24V DC output are placed in the same compartment

\*\* There is one set of output wires (1 red and 1 black) in 30W / 60W / 96W drivers, two sets of output wires in the 192W driver, three sets of output wires in the 288W driver

# WIRING AND DIMMING DIAGRAMS

## PHASE (ELV) DIMMING

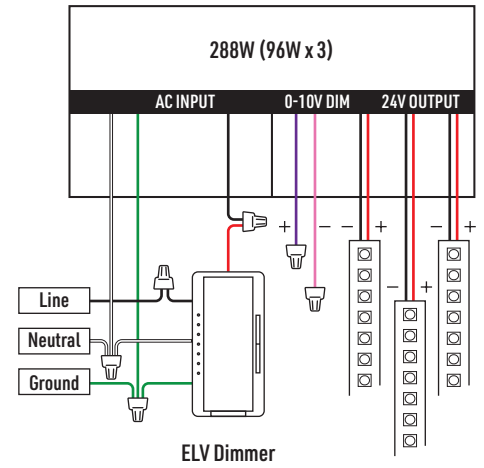
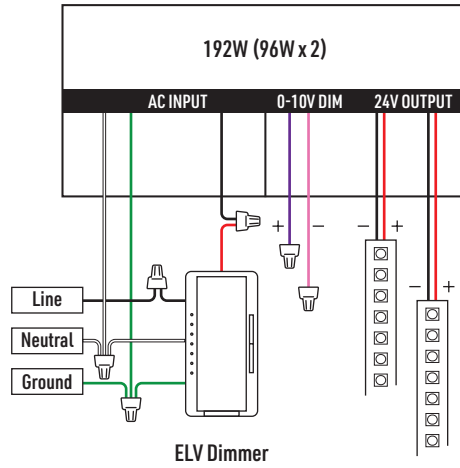
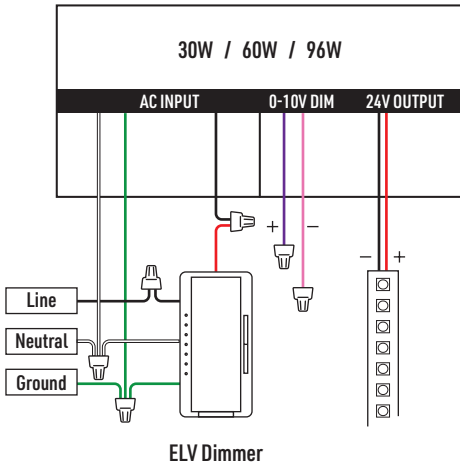

## PHASE (MLV / TRIAC) DIMMING

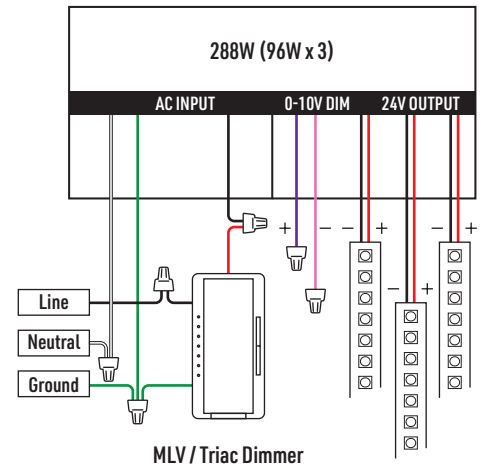
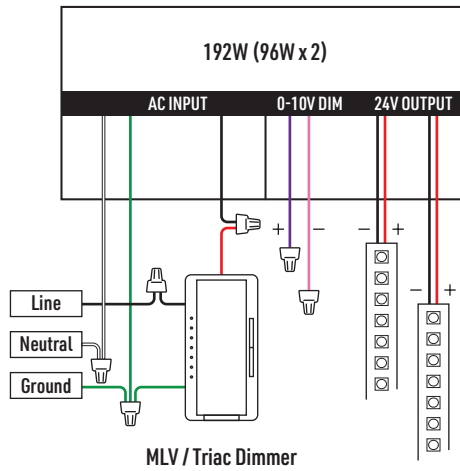
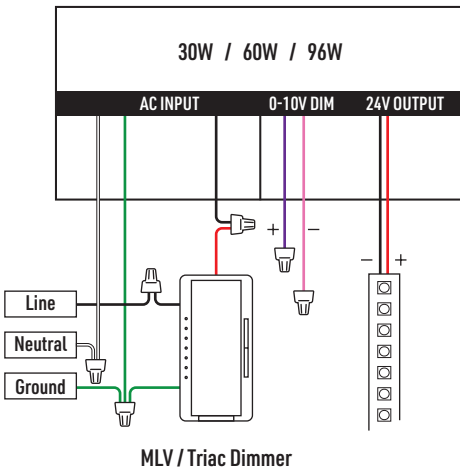

## 0-10V DIMMING

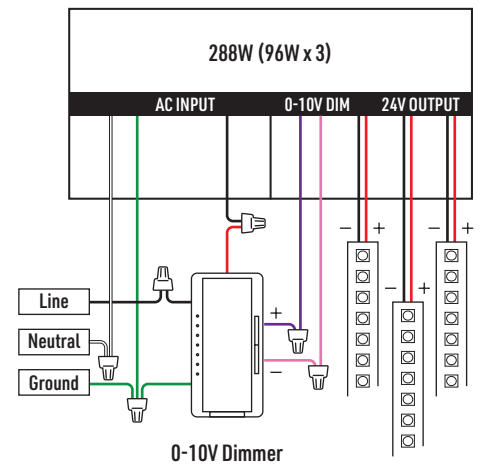
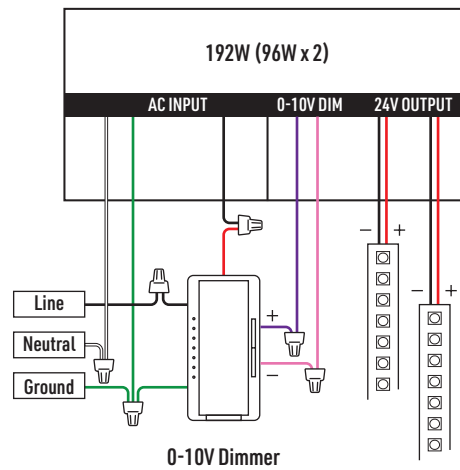
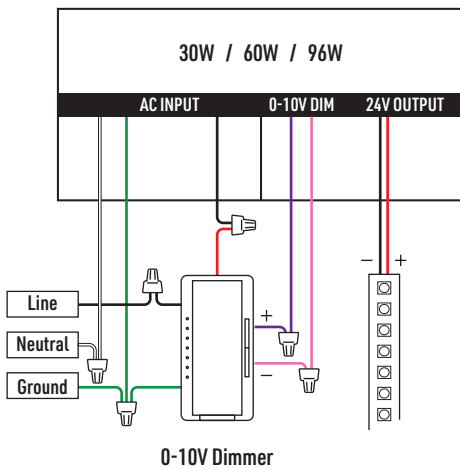

## UNDERSTANDING PWM (PULSE WIDTH MODULATION) AND VR (VOLTAGE REGULATION) DIMMING

Our universal 24V constant voltage drivers with adjustable voltage output support both Voltage Regulation (VR) Mode and Pulse Width Modulation (PWM) Mode, giving you flexible dimming options for different lighting applications:

- Easily switch between VR and PWM to match your lighting setup
- Ensures efficient, precise dimming across various systems

Perfect for **residential, commercial, and architectural lighting**, our drivers provide **universal compatibility with smooth, reliable dimming** performance.

### Pulse Width Modulation (PWM) Mode

Pulse Width Modulation (PWM) is a method for reducing the average deliverable power of an electrical signal. PWM dimming works by rapidly switching the LED on and off at high speed. The PWM signal may either be ON or OFF at any one time, meaning that the LEDs will either get the full or no voltage. The brightness is controlled by adjusting the time the LED is on versus off in each cycle. Since this happens faster than the human eye can detect, the LED appears to dim smoothly without changing its voltage. Best for commercial applications, ensures high-efficiency, precise dimming and color consistency for advanced lighting systems.

#### Benefits:

- Maintains consistent LED color and efficiency across dimming levels
- Provides smooth and precise dimming

#### Considerations:

- Low-quality dimmers may introduce flicker if the frequency is too low

#### Dimming Compatibility:

- 0-10V Dimming: the 0-10V signal is converted into a corresponding PWM signal to control brightness
- Phase-Cut Dimming: can work with MLV and ELV dimmers by interpreting the phase-cut signal to adjust the PWM duty cycle

### Voltage Regulation (VR) Mode:

In VR mode, the LED driver's DC output voltage is adjusted to control the brightness of the connected LEDs. Best for simple household applications and warmdim applications with basic dimming and minimal flicker.

#### Benefits:

- Simple and widely supported dimming method
- Works over long distances without signal degradation
- Compatible with most lighting control systems

#### Considerations:

- Less precise than PWM at very low brightness levels

#### Dimming Compatibility:

- 0-10V Dimming: utilizes a low-voltage control signal to adjust the output voltage
- Phase-Cut Dimming: works with both leading-edge (MLV) and trailing-edge (ELV) dimmers by modifying the AC waveform

## CLASS P DRIVERS

A **Class P driver** is a type of LED driver that follows **UL (Underwriters Laboratories)** standards for safety and performance. The main benefit is **interchangeability** – you can replace a Class P driver with another Class P driver (from any brand) **with same specifications** without needing to retest the entire lighting system for compliance.

#### Key Points:

- **Interchangeability** – Makes it easier to replace drivers without re-certification.
- **UL Safety Standard** – Ensures the driver meets thermal and electrical safety requirements.
- **Flexibility** – Manufacturers can switch to different Class P drivers based on availability or performance needs.